



SERVICE BULLETIN

Ultra Electronics Controls
417 Bridport Road, Greenford, Middlesex, UB6 8UE
United Kingdom
(CAGE: K8081)

Telephone: +44 (0) 20 8813 4444 Fax: +44 (0) 20 8813 4351
Email: support@ultra-controls.com

SERVICE BULLETIN No. 001SP-32-001

LANDING GEAR – NOSE WHEEL STEERING – STEERING DISCONNECT PANEL

INTRODUCTION OF SELF-LOCKING NUT ATTACHING PARTS FOR TOGGLE LATCH AND TOGGLE LATCH STRIKE (AMENDMENT C)

1. Planning Information

A. Effectivity

Steering Disconnect Panel, PNR: 001SP0005.

B. Concurrent Requirements

Not Applicable.

C. Reason

This Vendor Service Bulletin (VSB) introduces new attaching parts for the Steering Disconnect Panel Toggle Latch and Toggle Latch Strike mechanisms. The Toggle Latch and Toggle Latch Strike are used to secure the Steering Disconnect Panel access door on A380 aircraft.

COPYRIGHT © Ultra Electronics Limited, doing business as Ultra Electronics Controls, 2016.

PROPRIETARY – This document and the information contained herein are the property of Ultra Electronics Limited doing business as Ultra Electronics Controls. Recipient agrees to hold all such information in confidence and agrees it shall be used only in accordance with applicable agreements and shall not be used for any other purpose. Recipient agrees not to disclose such information to any third party as provided for in agreements. Copying or disclosure by anyone without written permission is not authorised and may result in criminal and/or civil liability.



SERVICE BULLETIN

D. Description

Ultra Electronics - Controls has identified that the Steering Disconnect Panel (PNR: 001SP0005) are being returned for repair with either a loose Toggle Latch or Toggle Latch Strike.

The Toggle Latch and Toggle Latch Strike existing attaching parts are as follows: M4 x 10 Screws, Plain Washers, Coil Spring Washers and M4 Nuts.

This amendment will replace the Coil Spring Washer and M4 Nut with Self-Locking Nuts, which will provide an improved locking mechanism to prevent the Toggle Latch and Toggle Latch Strike becoming loose. This change is identified and recorded on the Steering Disconnect Panel as Amendment C.

E. Compliance

Application of this Service Bulletin is desirable to introduce this improvement.

Ultra Electronics Controls will accomplish this Service Bulletin on Steering Disconnect Panels that are returned for a standard repair on an attrition basis; normal conditions and warranty terms will apply.

F. Approval

The modification procedures described in this VSB are reviewed and technically accepted by Airbus Design office to apply to the Airbus fleet affected.

This VSB does not contain any change information that revises the equipment definition covered by Airbus approved modifications.

G. Manpower

The time estimates given in the Service Bulletin are based on the direct labour to do the work. The estimates do not include the time to prepare, plan or inspect the work. Also procurement of parts and general administration work for the task are not included. The estimated time necessary to embody this Service Bulletin is as follows:

1. Disassembly: 2.5 man-hours.
2. Assembly: 1 man-hour.
3. Final Test: 2 man-hours.



SERVICE BULLETIN

- H. Weight and Balance
 - None.
 - I. Electrical Load Data
 - Not changed.
 - J. Software Accomplishment Summary
 - Not Applicable.
 - K. References
 - Equipment Definition Evolution Sheet, EDES 001SP/019, Issue 01.
 - Ultra Electronics Controls, Steering Disconnect Panel, Component Maintenance Manual (CMM) ATA Ref. No. 32-31-84 (Latest Revision).
 - L. Other Publications Affected
 - Not Applicable
 - M. Interchangeability of Parts
 - Fully interchangeable.
2. Material Information
- A. Material – Price and Availability
 - Price: The necessary material is detailed in paragraph 2.C.
 - Availability: Contact Ultra Electronics Controls for availability.



SERVICE BULLETIN

B. Industry Support Information

- (1) Ultra Electronics Controls will accomplish this Service Bulletin on Steering Disconnect Panels that are returned for a standard repair on an attrition basis; normal conditions and warranty terms will apply.
- (2) Notification.

After accomplishment of this VSB, the Operator must supply Ultra Electronics Controls with the following data:

- Service Bulletin number.
- Serial number(s) of the Steering Disconnect Panel (s) amended.
- Date of amendment(s).

Send this data to:

Customer Support Manager,
Ultra Electronics Controls
417 Bridport Road, Greenford, Middlesex,
UB6 8UE
United Kingdom

- (3) Further Information.

If you need more information about this Vendor Service Bulletin, or to obtain price/delivery data, contact the Customer Support Manager at:

Ultra Electronics Controls
417 Bridport Road, Greenford, Middlesex
UB6 8UE
United Kingdom

Telephone: +44 (0) 20 8813 4444 Fax: +44 (0) 20 8813 4351
Email: support@ultra-controls.com



SERVICE BULLETIN

C. Material Necessary for Each Component(Unit)

The following parts from Ultra Electronics Controls are necessary to accomplish this VSB.

(1) Material to be Purchased

<u>New PNR</u>	<u>Key Word</u>	<u>Old PNR</u>	<u>Qty</u>	<u>Unit Price</u>	<u>Inst/Disp</u>
K9813-052-0-8	Nut - Self-Locking	K1383-205-0-3	4	\$3.12 (World List Price 2016)	Replaced
010-MP-00-0009	Label - Amendment	N/A	1	\$26.74 (World List Price 2016)	New

(2) Material Supplied by the Operator (Consumables)

(a) Standard Material

Refer to the related sections of the CMM – Tools and Materials.

(b) Specific Material

Nil.

D. Material Necessary for Each Spare

Not Applicable.

E. Re-identified Parts

Not Applicable.

F. Tooling – Price and Availability

No special tools are required to accomplish this VSB.



SERVICE BULLETIN

3. Accomplishment Instructions

A. General

Full description of the procedures is described in the Steering Disconnect Panel CMM, ATA Ref. 32-31-84 (Latest Revision). In the following procedures, the Figure and Item numbers in parentheses refer to those used in the Detailed Parts List in the CMM Illustrated Part List. Do a unit inspection in accordance with Steering Disconnect Panel CMM, ATA Ref. 32-31-84, INSPECTION/CHECK, page 5001.

CAUTION: YOU MUST WORK ON THE STEERING DISCONNECT PANEL ONLY UNDER CLEAN ROOM CONDITIONS. USE APPROVED ANTI-STATIC PROCEDURES TO PREVENT STATIC DISCHARGE DAMAGE

B. Disassembly

Refer to the Steering Disconnect Panel CMM, ATA Ref. 32-31-84, DISASSEMBLY, page 3002.

(1) Steering Disconnect Panel – Disassembly (IPL Figure 1).

Disassemble the Steering Disconnect Panel as instructed in Paragraph 2.D. and remove the Steering Panel Fascia Panel sub-assembly (55) from the Steering Disconnect Panel (1).

(2) Toggle Latch Strike – Embodiment (IPL Figure 1)

- (a) Refer to the Steering Disconnect Panel CMM, ATA Ref. 32-31-84, REPAIR, page 6004.
- (b) Remove the Toggle Latch Strike (25) from Steering Disconnect Panel (1) access door, as instructed in Para 5.B.(1).
- (c) Retain the attaching parts, but discard the Coil Spring Washers (40) x2 and Nuts (45) x2.
- (d) Refit the Toggle Latch Strike (25) to Steering Disconnect Panel (1) access door and attached with Screws (30) x2. Install in the following order; Plain Washer (35) and new Self-Locking Nut. Torque tighten to 3.0 ± 0.3 Nm (26.5 ± 2.6 lb.in.).



SERVICE BULLETIN

- (3) Toggle Latch – Embodiment (IPL Figure 4)
 - (a) Refer to the Steering Disconnect Panel CMM, ATA Ref. 32-31-84, REPAIR, page 6004.
 - (b) Remove the Toggle Latch (15) from Steering Panel Box (1) as instructed in Para 5.C.(2).
 - (c) Retain the attaching parts, but discard the Coil Spring Washers (30) x2 and Nuts (35) x2.
 - (d) Refit the Toggle Latch (15) to Steering Panel Box (1) and attach with Screws (20) x2. Install in the following order; Plain Washer (25) and new Self-Locking Nut. Torque tighten to 3.0 ± 0.3 Nm (26.5 ± 2.6 lb.in.).

C. Assembly

Refer to the Steering Disconnect Panel CMM, ATA Ref. 32-31-84, ASSEMBLY, page 7006.

- (1) Steering Disconnect Panel – Assembly (IPL Figure 1).

Assemble the Steering Disconnect Panel as instructed in Paragraph 2.A. and refit the Steering Panel Fascia Panel sub-assembly (55) to the Steering Disconnect Panel (1).

D. Re-identification of Parts

NOTE: Early production serial numbers of the Steering Disconnect Panel are not fitted with an Amendment Label.

- (1) If the Steering Disconnect Panel is fitted with an Amendment Label go to Para. 3.D.6.
- (2) If the fitment of an Amendment Label is required, carry out the following instructions.
- (3) Refer to Figure 1 and locally clean the area with IPA and allow to dry. Make sure the area is clean and free of grease.
- (4) Remove protective backing from the new Amendment Label and place in position as shown in Figure 1.



SERVICE BULLETIN

- (5) Apply even pressure across the Amendment Label to make sure the Label is secure.
- (6) Strike through Label "C" to indelibly identify the Steering Disconnect Panel as Amendment C.

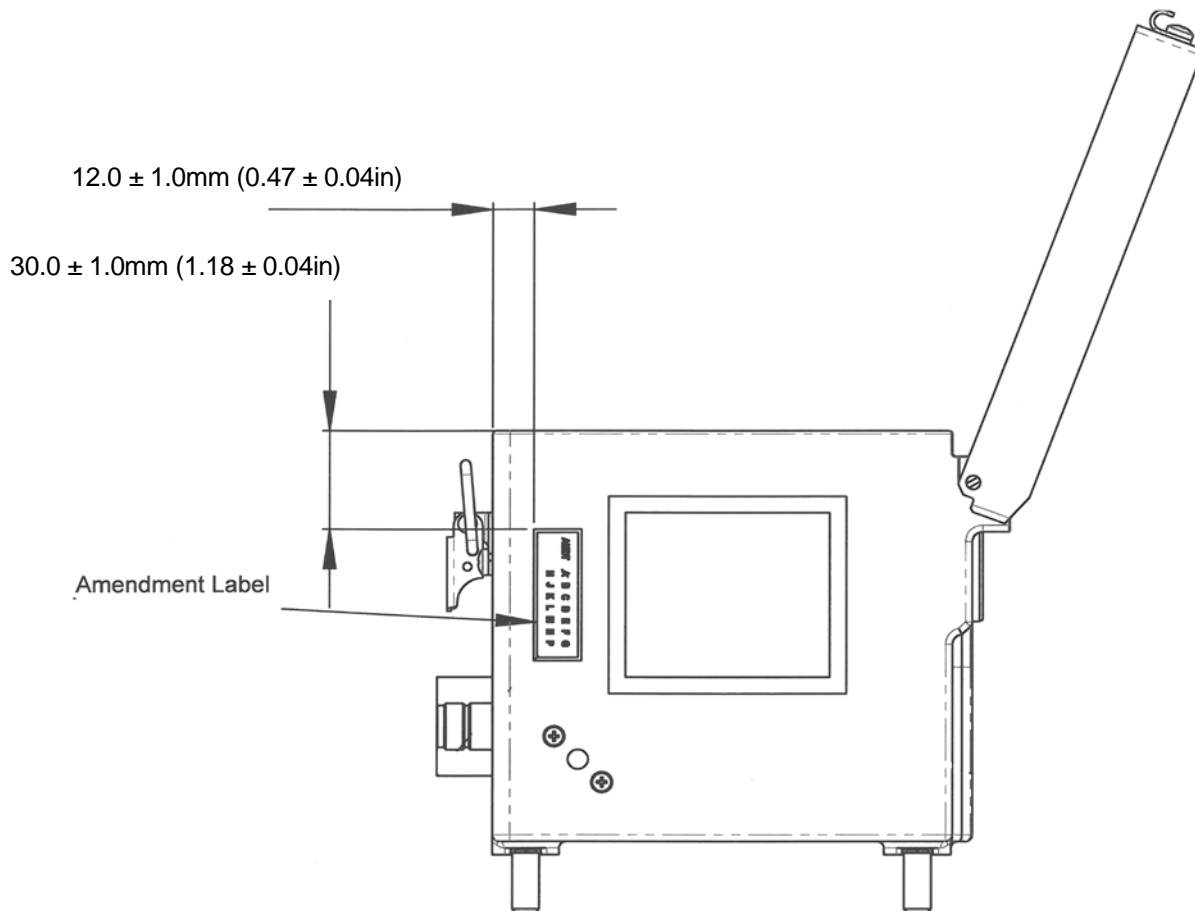

FIGURE 1 - Amendment Label - Location



SERVICE BULLETIN

E. Test

- (1) Refer to the Steering Disconnect Panel CMM, ATA Ref. 32-31-84, TESTING AND FAULT ISOLATION page 1001.
- (2) Perform a full acceptance test on the Steering Disconnect Panel in accordance with TESTING AND FAULT ISOLATION page 1001.



SERVICE BULLETIN

This Page Intentionally Left Blank